

Instruction Manual

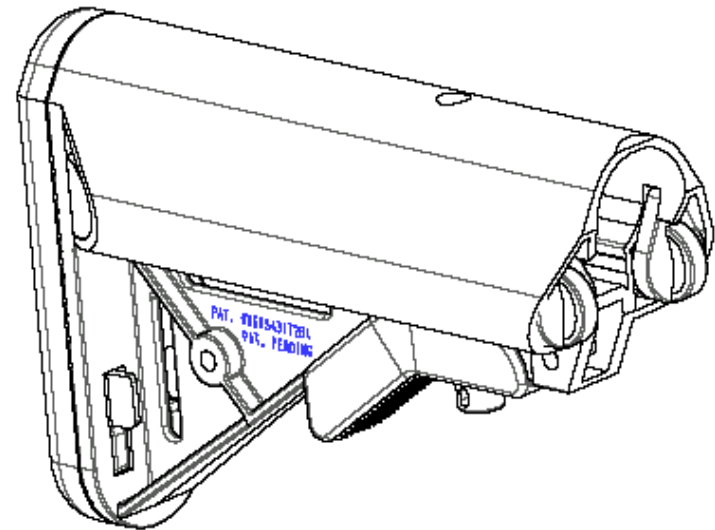

**Sopmod Buttstock and Battery
Tube Components
L7LA2B**



Removing Buttstock from Extension Tube

- Grasp the release lever (6) on the checkered end. While pulling the release lever away from the buttstock, slide the buttstock (2) off the end of the extension tube (5).

Removing Battery Tubes from Buttstock

- After removing the buttstock from the extension tube, grasp the battery tube cap (4) and turn towards the opening. When the cap clears the opening, pull the battery tube (3) from the buttstock.
***Note, the flat sides that run the length of the battery tubes are positioned towards the center of the buttstock against the flat in the tube compartment. Ensure while replacing the tubes that the caps are fully rotated into the slot and the flats are against their mating flat surface.

Removing End Plate from Buttstock

- Grasp both tabs (7) simultaneously on the end plate (1). Apply inward force to both tabs while pulling the end plate away from the buttstock.
***Note, the removal of buttpad is needed only when replacing a worn pad. Removal may result in retaining tab breakage that is not covered under warranty.

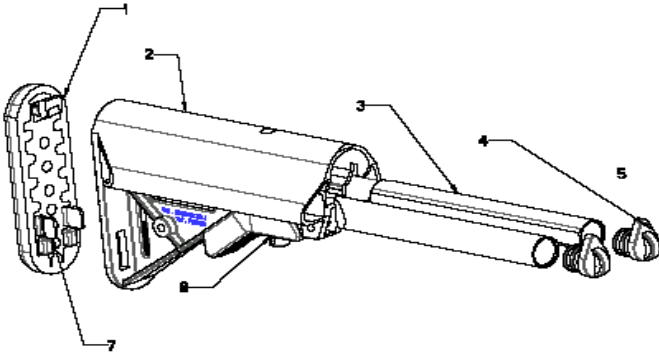

Rev A

For questions, or further information, please contact:

Lewis Machine & Tool Company

1305 W. 11th Street

Milan, IL. 61264

Phone: 309-787-7151

Fax: 309-787-7193

Email: sales@lewismachine.net